

Turbo-Dot: Electro-pneumatic Jet Valve

High-precision micro-dispensing: accurate, stable, flexible and fast



The TD118AN electro-pneumatic high-performance jet valve is designed for the contactless microdispensing of anaerobic media. This is made possible by using a ceramic tappet and components made of PEEK. A micro-dosing volume of 2nL or larger can be dispensed at frequencies as high as 280 Hz. Allowing the valve to dispense single dots as well as lines. The definable dot sizes range from 0.3 mm up to 5.0 mm in diameter depending on the media. Dispensing distances between valve and component are usually within 0.5 mm and 10.0 mm.

The Turbo-Dot Jet Valve has easily exchangeable dispensing nozzles, tappets, and fluid inlet fittings. Thereby making it customizable for different application requirements. Our quick and easy tappet stroke adjustment yields precise and repeatable results. Only three parts, which are separated from the actuator, come in contact with the medium, making the valve easy to clean and maintain.

The Turbo-Dot valves operate electro-pneumatically at low voltages although the control signal can be adjusted manually. The valves have a minimal dilation time of 2 ms before the stream-forming dispensation can occur. The dispensation cycle ends with the recession of the control signal and the closing of the valve (closed without power supply).

The valves are cost-efficient and perfect for industrial production due to their robust and proven construction.

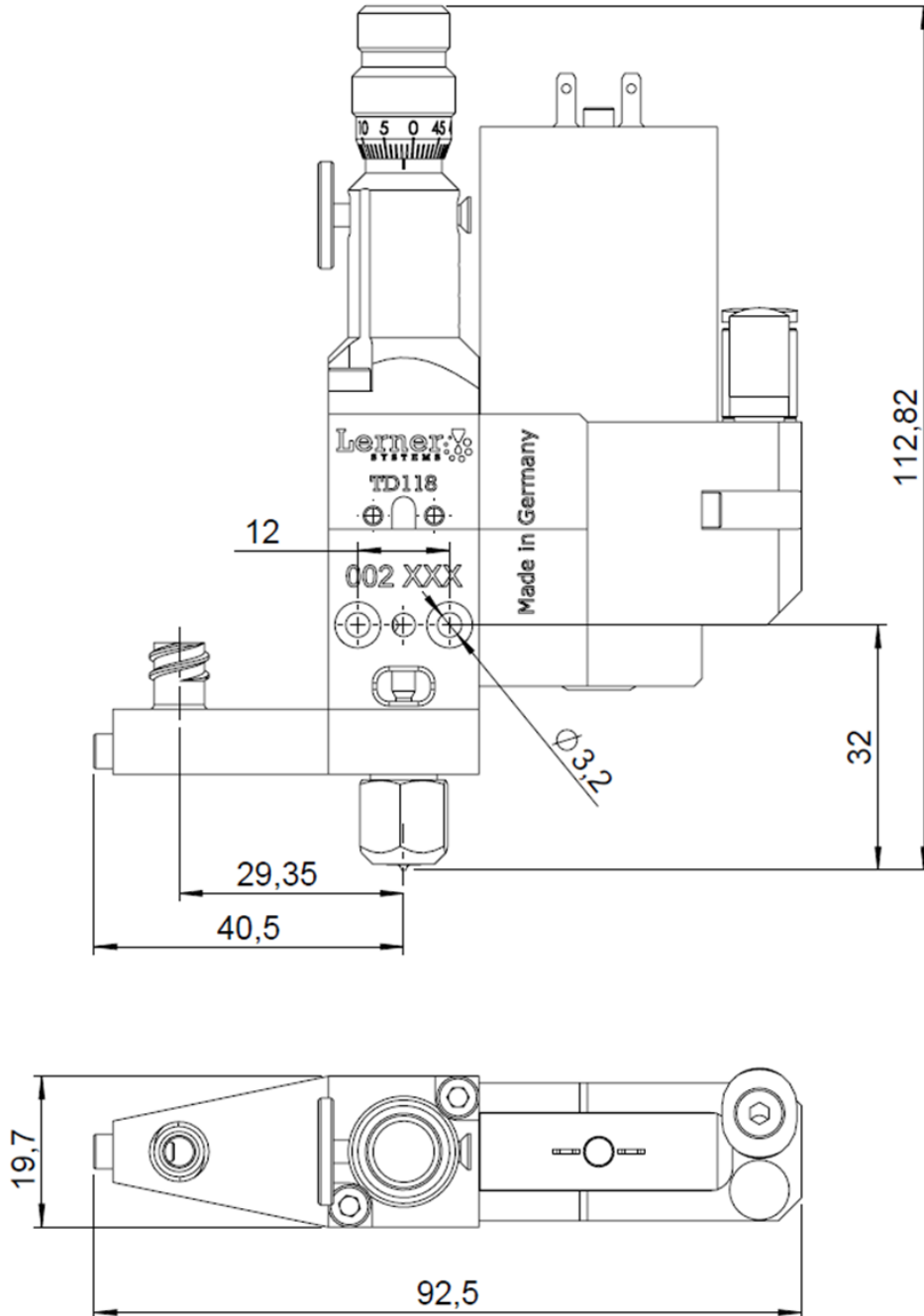

Specifications

Name	TD118AN
Measurements	19.7W x 112H x 61L mm
Weight	204 g (7.2 oz)
Mounting	M3 x 25
Input voltage	24 VDC
Power consumption	0.2 Amp (peak 1 Amp)
Valve opening time	from 2 ms
Maximum operating frequency	280 Hz
Maximum nozzle heating temperature	90°C (194° F)
Maximum operating temperature	40°C (104° F)
Storage temperature	-5–60 °C (23–140° F)
Operating air pressure	4-7 bar (58-100 psi)
Maximum fluid pressure	100 bar (1450 psi)
Humidity	10-80%
Viscosity range	0.5-100,000 mPas (thixotropic)
Dispensing volume	from 2 nL in one cycle
Dispensing accuracy	>98%
Quality of compressed air	Degree of contamination DIN ISO 8573-1, class 5

NOTE. Performances and specifications are subject to change without notice.